



DW-40L262



Hydrocarbon (HC)
Energy-saving



Environmentally
Friendly



Low Noise



Security Lock

-40°C Biomedical Freezer

Scope of Application

The product is designed to store vaccines, blood plasma and many other biological materials. Installations can be found in research institutions and clinical sites in the life science, pharma, biotech, medical and electronics sectors.

Innovative Design

- Hydrocarbon (HC) Energy-saving
- Environmentally Friendly
- Low Noise
- Security Lock

Haier Biomedical Co.,Ltd.

No.280 Feng Yuan Road, High-tech Zone,
Qingdao, 266109, P.R. China
E-mail: inquiry@haierbiomedical.com
Website: www.haiermedical.com



Haier Biomedical
International



Haier Biomedical
International



@haiermedicalint



Haier Biomedical
International



Haier Biomedical
International

Product Features



Energy Saving And Environmental Protection

Microprocessor electronic temperature controller, LCD digital temperature display, display precision is 0.1°C, temperature set point -20~-40°C. Multiple alarms including high and low temperature, sensor error, power failure, door ajar, high ambient and remote alarm. Alarm mode: sound and light alarm. It can be connected to remote alarm.



Porthole

There is a standard access port (25mm inside diameter) on the left side of the unit, which is convenient for users to test independently.



High Uniformity

DW-40L262 cools down to -40°C from 25°C ambient in around 170 minutes due to the optimized HC refrigeration system.



Low Energy Consumption

The power consumption of DW-40L262 decreases from 4.3 KW·h/day to 2.62 KW·h/day, and the energy consumption is reduced by more than 35%.



Multiple Interface Options

Standard configuration: Remote alarm interface.
Optional configuration: USB or RS485.



Low Noise

DW-40L262 noise decreases to 41dB, quiet and low noise.

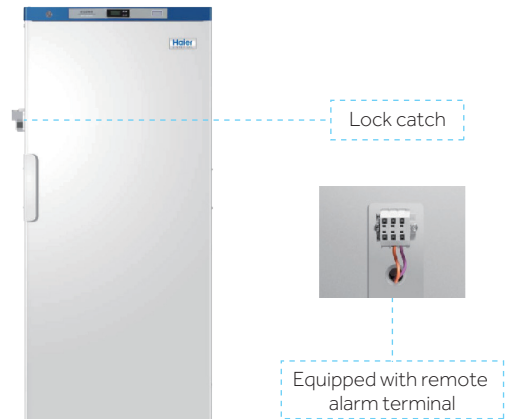

Product Dimension Drawings

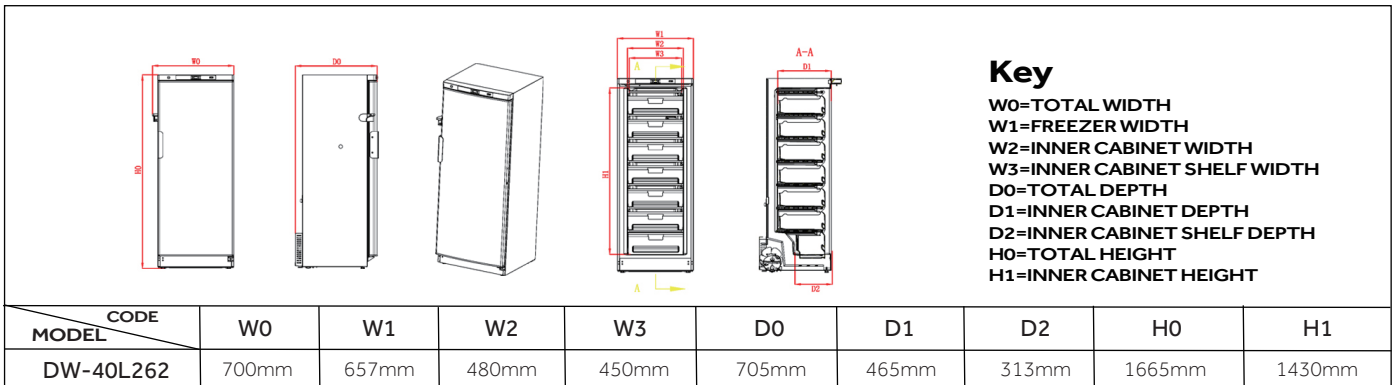

Specifications

Cabinet Type	Climate Class	Cooling Type	Defrost Mode	Refrigerant	Sound Level (dB(A))	Cooling Performance (°C)	Temperature Range (°C)	Controller	Display	Power Supply (V/Hz)	Power (W)
Upright	SNN	Direct Cooling	Manual	HC CFC-Free	41 44	-40	-20~-40	Microprocessor	LCD	220-240/50/60 115/60	310 600
Electrical Current (A)	Power Consumption (kW·h/24h)	Capacity (L/Cu.Ft)	Net/Gross Weight(approx)(kg)(lbs)	Internal Dimension(W*D*H)(mm)(in)							
2 7.5	2.6 4.3	262/9.3	88/93 194.0/205.0	480*465*1430 18.9*18.3*56.3							
Exterior Dimension (W*D*H)(mm)(in)	Packing Dimensions (W*D*H)(mm)(in)	Container Load (20'/40'/40'H)	Alarms	Accessories	Certification						
700*705*1665 27.6*27.8*65.6	775*760*1880 30.5*29.9*74.0	21/45/45	High/Low Temperature, Remote Alarm, Power Failure, Sensor Error, High Ambient Temperature, Door Ajar	Caster, Foot, Porthole, Drawers/Inner Doors(3/-), USB Interface(Optional), RS485(Optional)	CE						

*Haier Biomedical reserves the right to change products and specifications without prior notice.